

Internet Engineering Task Force (IETF)
Request for Comments: 5976
Category: Experimental
ISSN: 2070-1721

G. Ash
A. Morton
M. Dolly
P. Tarapore
C. Dvorak
AT&T Labs
Y. El Mghazli
Alcatel-Lucent
October 2010

Y.1541-QOSM: Model for Networks Using Y.1541 Quality-of-Service Classes

Abstract

This document describes a QoS-NSLP Quality-of-Service model (QOSM) based on ITU-T Recommendation Y.1541 Network QoS Classes and related guidance on signaling. Y.1541 specifies 8 classes of Network Performance objectives, and the Y.1541-QOSM extensions include additional QSPEC parameters and QOSM processing guidelines.

Status of This Memo

This document is not an Internet Standards Track specification; it is published for examination, experimental implementation, and evaluation.

This document defines an Experimental Protocol for the Internet community. This document is a product of the Internet Engineering Task Force (IETF). It represents the consensus of the IETF community. It has received public review and has been approved for publication by the Internet Engineering Steering Group (IESG). Not all documents approved by the IESG are a candidate for any level of Internet Standard; see Section 2 of RFC 5741.

Information about the current status of this document, any errata, and how to provide feedback on it may be obtained at <http://www.rfc-editor.org/info/rfc5976>.

Copyright Notice

Copyright (c) 2010 IETF Trust and the persons identified as the document authors. All rights reserved.

This document is subject to BCP 78 and the IETF Trust's Legal Provisions Relating to IETF Documents (<http://trustee.ietf.org/license-info>) in effect on the date of publication of this document. Please review these documents

carefully, as they describe your rights and restrictions with respect to this document. Code Components extracted from this document must include Simplified BSD License text as described in Section 4.e of the Trust Legal Provisions and are provided without warranty as described in the Simplified BSD License.

This document may contain material from IETF Documents or IETF Contributions published or made publicly available before November 10, 2008. The person(s) controlling the copyright in some of this material may not have granted the IETF Trust the right to allow modifications of such material outside the IETF Standards Process. Without obtaining an adequate license from the person(s) controlling the copyright in such materials, this document may not be modified outside the IETF Standards Process, and derivative works of it may not be created outside the IETF Standards Process, except to format it for publication as an RFC or to translate it into languages other than English.

Table of Contents

- 1. Introduction 3
 - 1.1. Requirements Language 3
- 2. Summary of ITU-T Recommendations Y.1541 and Signaling Requirements 3
 - 2.1. Description of Y.1541 Classes 4
 - 2.2. Y.1541-QOSM Processing Requirements 6
- 3. Additional QSPEC Parameters for Y.1541 QOSM 7
 - 3.1. Traffic Model (TMOD) Extension Parameter 7
 - 3.2. Restoration Priority Parameter 8
- 4. Y.1541-QOSM Considerations and Processing Example 10
 - 4.1. Deployment Considerations 10
 - 4.2. Applicable QSPEC Procedures 10
 - 4.3. QNE Processing Rules 10
 - 4.4. Processing Example 10
 - 4.5. Bit-Level QSPEC Example 12
 - 4.6. Preemption Behavior 14
- 5. IANA Considerations 14
 - 5.1. Assignment of QSPEC Parameter IDs 14
 - 5.2. Restoration Priority Parameter Registry 14
 - 5.2.1. Restoration Priority Field 14
 - 5.2.2. Time to Restore Field 15
 - 5.2.3. Extent of Restoration Field 15
- 6. Security Considerations 16
- 7. Acknowledgements 16
- 8. References 17
 - 8.1. Normative References 17
 - 8.2. Informative References 17

1. Introduction

This document describes a QoS model (QOSM) for Next Steps in Signaling (NSIS) QoS signaling layer protocol (QoS-NSLP) application based on ITU-T Recommendation Y.1541 Network QoS Classes and related guidance on signaling. [Y.1541] currently specifies 8 classes of Network Performance objectives, and the Y.1541-QOSM extensions include additional QSPEC [RFC5975] parameters and QOSM processing guidelines. The extensions are based on standardization work in the ITU-T on QoS signaling requirements ([Y.1541] and [E.361]), and guidance in [TRQ-QoS-SIG].

[RFC5974] defines message types and control information for the QoS-NSLP that are generic to all QOSMs. A QOSM is a defined mechanism for achieving QoS as a whole. The specification of a QOSM includes a description of its QSPEC parameter information, as well as how that information should be treated or interpreted in the network. The QSPEC [RFC5975] contains a set of parameters and values describing the requested resources. It is opaque to the QoS-NSLP and similar in purpose to the TSpec, RSpec, and AdSpec specified in [RFC2205] and [RFC2210]. A QOSM provides a specific set of parameters to be carried in the QSPEC object. At each QoS NSIS Entity (QNE), the QSPEC contents are interpreted by the resource management function (RMF) for purposes of policy control and traffic control, including admission control and configuration of the scheduler.

1.1. Requirements Language

The key words "MUST", "MUST NOT", "REQUIRED", "SHALL", "SHALL NOT", "SHOULD", "SHOULD NOT", "RECOMMENDED", "MAY", and "OPTIONAL" in this document are to be interpreted as described in RFC 2119 [RFC2119].

2. Summary of ITU-T Recommendations Y.1541 and Signaling Requirements

As stated above, [Y.1541] is a specification of standardized QoS classes for IP networks (a summary of these classes is given below). Section 7 of [TRQ-QoS-SIG] describes the signaling features needed to achieve end-to-end QoS in IP networks, with Y.1541 QoS classes as a basis. [Y.1541] recommends a flexible allocation of the end-to-end performance objectives (e.g., delay) across networks, rather than a fixed per-network allocation. NSIS protocols already address most of the requirements; this document identifies additional QSPEC parameters and processing requirements needed to support the Y.1541 QOSM.

2.1. Description of Y.1541 Classes

[Y.1541] proposes grouping services into QoS classes defined according to the desired QoS performance objectives. These QoS classes support a wide range of user applications. The classes group objectives for one-way IP packet delay, IP packet delay variation, IP packet loss ratio, etc., where the parameters themselves are defined in [Y.1540].

Note that [Y.1541] is maintained by the ITU-T and subject to occasional updates and revisions. The material in this section is provided for information and to make this document easier to read. In the event of any discrepancies, the normative definitions found in [Y.1541] take precedence.

Classes 0 and 1 might be implemented using the Diffserv Expedited Forwarding (EF) Per-Hop Behavior (PHB), and they support interactive real-time applications [RFC3246]. Classes 2, 3, and 4 might be implemented using the Diffserv Assured Forwarding (AFxy) PHB Group, and they support data transfer applications with various degrees of interactivity [RFC2597]. Class 5 generally corresponds to the Diffserv Default PHB, and it has all the QoS parameters unspecified consistent with a best-effort service [RFC2474]. Classes 6 and 7 provide support for extremely loss-sensitive user applications, such as high-quality digital television, Time Division Multiplexing (TDM) circuit emulation, and high-capacity file transfers using TCP. These classes are intended to serve as a basis for agreements between end-users and service providers, and between service providers. They support a wide range of user applications including point-to-point telephony, data transfer, multimedia conferencing, and others. The limited number of classes supports the requirement for feasible implementation, particularly with respect to scale in global networks.

The QoS classes apply to a packet flow, where [Y.1541] defines a packet flow as the traffic associated with a given connection or connectionless stream having the same source host, destination host, class of service, and session identification. The characteristics of each Y.1541 QoS class are summarized here:

Class 0:

Real-time, highly interactive applications, sensitive to jitter.
Mean delay ≤ 100 ms, delay variation ≤ 50 ms, and loss ratio $\leq 10^{-3}$. Application examples include VoIP and video teleconference.

Class 1:

Real-time, interactive applications, sensitive to jitter. Mean delay ≤ 400 ms, delay variation ≤ 50 ms, and loss ratio $\leq 10^{-3}$. Application examples include VoIP and video teleconference.

Class 2:

Highly interactive transaction data. Mean delay ≤ 100 ms, delay variation is unspecified, loss ratio $\leq 10^{-3}$. Application examples include signaling.

Class 3:

Interactive transaction data. Mean delay ≤ 400 ms, delay variation is unspecified, loss ratio $\leq 10^{-3}$. Application examples include signaling.

Class 4:

Low Loss Only applications. Mean delay ≤ 1 s, delay variation is unspecified, loss ratio $\leq 10^{-3}$. Application examples include short transactions, bulk data, and video streaming.

Class 5:

Unspecified applications with unspecified mean delay, delay variation, and loss ratio. Application examples include traditional applications of default IP networks.

Class 6:

Applications that are highly sensitive to loss. Mean delay ≤ 100 ms, delay variation ≤ 50 ms, and loss ratio $\leq 10^{-5}$. Application examples include television transport, high-capacity TCP transfers, and Time-Division Multiplexing (TDM) circuit emulation.

Class 7:

Applications that are highly sensitive to loss. Mean delay ≤ 400 ms, delay variation ≤ 50 ms, and loss ratio $\leq 10^{-5}$. Application examples include television transport, high-capacity TCP transfers, and TDM circuit emulation.

These classes enable service level agreements (SLAs) to be defined between customers and network service providers with respect to QoS requirements. The service provider then needs to ensure that the requirements are recognized and receive appropriate treatment across network layers.

Work is in progress to specify methods for combining local values of performance metrics to estimate the performance of the complete path. See Section 8 of [Y.1541], [RFC5835], and [COMPOSITION].

2.2. Y.1541-QOSM Processing Requirements

[TRQ-QoS-SIG] guides the specification of signaling information for IP-based QoS at the interface between the user and the network (UNI) and across interfaces between different networks (NNI). To meet specific network performance requirements specified for the Y.1541 QoS classes [Y.1541], a network needs to provide specific user-plane functionality at the UNI and NNI. Dynamic network provisioning at a UNI and/or NNI node allows a traffic contract for an IP flow to be dynamically requested from a specific source node to one or more destination nodes. In response to the request, the network determines if resources are available to satisfy the request and provision the network.

For implementations to claim compliance with this memo, it **MUST** be possible to derive the following service-level parameters as part of the process of requesting service:

- a. Y.1541 QoS class, 32-bit integer, range: 0-7
- b. rate (r), octets per second
- c. peak rate (p), octets per second
- d. bucket size (b), octets
- e. maximum packet size (MPS), octets, IP header + IP payload
- f. Diffserv PHB class [RFC2475]
- g. admission priority, 32-bit integer, range: 0-2

Compliant implementations **MAY** derive the following service-level parameters as part of the service request process:

- h. peak bucket size (Bp), octets, 32-bit floating point number in single-precision IEEE floating point format [IEEE754]
- i. restoration priority, multiple integer values defined in Section 3 below

All parameters except Bp and restoration priority have already been specified in [RFC5975]. These additional parameters are defined as

- o Bp, the size of the peak-rate bucket in a dual-token bucket arrangement, essentially setting the maximum length of bursts in the peak-rate stream. For example, see Annex B of [Y.1221]

- o restoration priority, as defined in Section 3 of this memo

Their QSPEC Parameter format is specified in Section 3.

It MUST be possible to perform the following QoS-NSLP signaling functions to meet Y.1541-QOSM requirements:

- a. accumulate delay, delay variation, and loss ratio across the end-to-end connection, which may span multiple domains.
- b. enable negotiation of Y.1541 QoS class across domains.
- c. enable negotiation of delay, delay variation, and loss ratio across domains.

These signaling requirements are supported in [RFC5974], and the functions are illustrated in Section 4 of this memo.

3. Additional QSPEC Parameters for Y.1541 QOSM

The specifications in this section extend the QSPEC [RFC5975].

3.1. Traffic Model (TMOD) Extension Parameter

The traffic model (TMOD) extension parameter is represented by one floating point number in single-precision IEEE floating point format and one 32-bit reserved field.

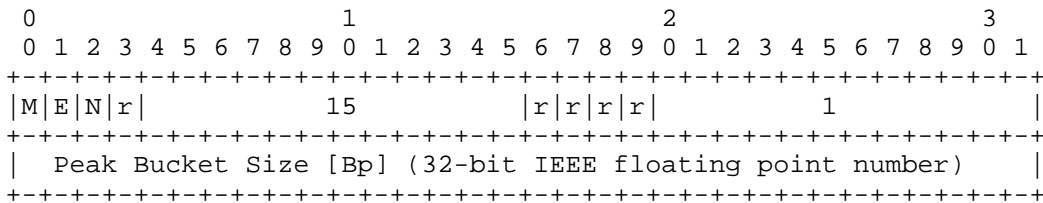

Figure 1: TMOD Extension

The Peak Bucket Size term, Bp, is represented as an IEEE floating point value [IEEE754] in units of octets. The sign bit MUST be zero (all values MUST be non-negative). Exponents less than 127 (i.e., 0) are prohibited. Exponents greater than 162 (i.e., positive 35) are discouraged, except for specifying a peak rate of infinity. Infinity is represented with an exponent of all ones (255), and a sign bit and mantissa of all zeros.

The QSPEC parameter behavior for the TMOD extended parameter follows that defined in Section 3.3.1 of [RFC5975]. The new parameter (and all traffic-related parameters) are specified independently from the Y.1541 class parameter.

3.2. Restoration Priority Parameter

Restoration priority is the urgency with which a service requires successful restoration under failure conditions. Restoration priority is achieved by provisioning sufficient backup capacity, as necessary, and allowing relative priority for access to available bandwidth when there is contention for restoration bandwidth. Restoration priority is defined as follows:

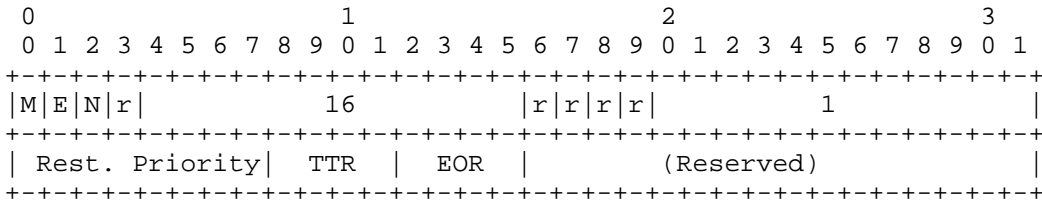

Figure 2: Restoration Priority Parameter

This parameter has three fields and a reserved area, as defined below.

Restoration Priority Field (8-bit unsigned integer): 3 priority values are listed here in the order of lowest priority to highest priority:

- 0 - best effort
- 1 - normal
- 2 - high

These priority values are described in [Y.2172], where best-effort priority is the same as Priority level 3, normal priority is Priority level 2, and high priority is Priority level 1. There are several ways to elaborate on restoration priority, and the two current parameters are described below.

Time-to-Restore (TTR) Field (4-bit unsigned integer): Total amount of time to restore traffic streams belonging to a given restoration class impacted by the failure. This time period depends on the technology deployed for restoration. A fast recovery period of < 200 ms is based on current experience with

Synchronous Optical Network (SONET) rings and a slower recovery period of 2 seconds is suggested in order to enable a voice call to recover without being dropped. Accordingly, TTR restoration suggested ranges are:

- 0 - Unspecified Time-to-Restore
- 1 - Best Time-to-Restore: ≤ 200 ms
- 2 - Normal Time-to-Restore ≤ 2 s

Extent of Restoration (EOR) Field (4-bit unsigned integer):

Percentage of traffic belonging to the restoration class that can be restored. This percentage depends on the amount of spare capacity engineered. All high-priority restoration traffic, for example, may be "guaranteed" at 100% by the service provider. Other classes may offer lesser chances for successful restoration. The restoration extent for these lower priority classes depend on SLAs developed between the service provider and the customer.

EOR values are assigned as follows:

- 0 - unspecified EOR
- 1 - high priority restored at 100%;
medium priority restored at 100%
- 2 - high priority restored at 100%;
medium priority restored at 80%
- 3 - high priority restored $\geq 80\%$;
medium priority restored $\geq 80\%$
- 4 - high priority restored $\geq 80\%$;
medium priority restored $\geq 60\%$
- 5 - high priority restored $\geq 60\%$;
medium priority restored $\geq 60\%$

Reserved: These 2 octets are reserved. The Reserved bits MAY be designated for other uses in the future. Senders conforming to this version of the Y.1541 QOSM SHALL set the Reserved bits to zero. Receivers conforming to this version of the Y.1541 QOSM SHALL ignore the Reserved bits.

4. Y.1541-QOSM Considerations and Processing Example

In this section, we illustrate the operation of the Y.1541 QOSM, and show how current QoS-NSLP and QSPEC functionality is used. No new processing capabilities are required to enable the Y.1541 QOSM (excluding the two OPTIONAL new parameters specified in Section 3).

4.1. Deployment Considerations

[TRQ-QoS-SIG] emphasizes the deployment of Y.1541 QNEs at the borders of supporting domains. There may be domain configurations where interior QNEs are desirable, and the example below addresses this possibility.

4.2. Applicable QSPEC Procedures

All procedures defined in Section 5.3 of [RFC5975] are applicable to this QOSM.

4.3. QNE Processing Rules

Section 7 of [TRQ-QoS-SIG] describes the information processing in Y.1541 QNEs.

Section 8 of [Y.1541] defines the accumulation rules for individual performance parameters (e.g., delay, jitter).

When a QoS NSIS initiator (QNI) specifies the Y.1541 QoS Class number, <Y.1541 QoS Class>, it is a sufficient specification of objectives for the <Path Latency>, <Path Jitter>, and <Path BER> parameters. As described in Section 2, some Y.1541 Classes do not set objectives for all the performance parameters above. For example, Classes 2, 3, and 4 do not specify an objective for <Path Jitter> (referred to as IP Packet Delay Variation). In the case that the QoS Class leaves a parameter unspecified, then that parameter need not be included in the accumulation processing.

4.4. Processing Example

As described in the example given in Section 3.4 of [RFC5975] and as illustrated in Figure 3, the QoS NSIS initiator (QNI) initiates an end-to-end, interdomain QoS NSLP RESERVE message containing the Initiator QSPEC. In the case of the Y.1541 QOSM, the Initiator QSPEC specifies the <Y.1541 QoS Class>, <TMOD>, <TMOD Extension>, <Admission Priority>, <Restoration Priority>, and perhaps other QSPEC parameters for the flow. As described in Section 3, the TMOD

extension parameter contains the OPTIONAL Y.1541-QOSM-specific terms; restoration priority is also an OPTIONAL Y.1541-QOSM-specific parameter.

As Figure 3 below shows, the RESERVE message may cross multiple domains supporting different QOSMs. In this illustration, the Initiator QSPEC arrives in a QoS NSLP RESERVE message at the ingress node of the local-QOSM domain. As described in [RFC5974] and [RFC5975], at the ingress edge node of the local-QOSM domain, the end-to-end, interdomain QoS-NSLP message may trigger the generation of a Local QSPEC, and the Initiator QSPEC is encapsulated within the messages signaled through the local domain. The Local QSPEC is used for QoS processing in the local-QOSM domain, and the Initiator QSPEC is used for QoS processing outside the local domain. As specified in [RFC5975], if any QNE cannot meet the requirements designated by the Initiator QSPEC to support an optional QSPEC parameter (i.e., with the M bit set to zero for the parameter), the QNE sets the N flag (not supported flag) for the parameter to one. For example, if the QNE cannot support the accumulation of end-to-end delay with the <Path Latency> parameter, where the M flag for the <Path Latency> parameter is set to zero denoting <Path Latency> as an optional parameter, the QNE sets the N flag (not supported flag) for the <Path Latency> parameter to one.

Also, the Y.1541-QOSM requires negotiation of the <Y.1541 QoS Class> across domains. This negotiation can be done with the use of the existing procedures already defined in [RFC5974]. For example, the QNI sets <Desired QoS>, <Minimum QoS>, and <Available QoS> objects to include <Y.1541 QoS Class>, which specifies objectives for the <Path Latency>, <Path Jitter>, and <Path BER> parameters. In the case that the QoS Class leaves a parameter unspecified, then that parameter need not be included in the accumulation processing. The QNE/domain SHOULD set the Y.1541 class and cumulative parameters, e.g., <Path Latency>, that can be achieved in the <QoS Available> object (but not less than specified in <Minimum QoS>). This could include, for example, setting the <Y.1541 QoS Class> to a lower class than specified in <QoS Desired> (but not lower than specified in <Minimum QoS>). If the <Available QoS> fails to satisfy one or more of the <Minimum QoS> objectives, the QNE/domain notifies the QNI and the reservation is aborted. Otherwise, the QoS NSIS Receiver (QNR) notifies the QNI of the <QoS Available> for the reservation.

When the available <Y.1541 QoS Class> must be reduced from the desired <Y.1541 QoS Class> (say, because the delay objective has been exceeded), then there is an incentive to respond with an available value for delay in the <Path Latency> parameter. If the available <Path Latency> is 150 ms (still useful for many applications) and the desired QoS is Class 0 (with its 100 ms objective), then the response

would be that Class 0 cannot be achieved, and Class 1 is available (with its 400 ms objective). In addition, this QOSM allows the response to include an available <Path Latency> = 150 ms, making acceptance of the available <Y.1541 QoS Class> more likely. There are many long paths where the propagation delay alone exceeds the Y.1541 Class 0 objective, so this feature adds flexibility to commit to exceed the Class 1 objective when possible.

This example illustrates Y.1541-QOSM negotiation of <Y.1541 QoS Class> and cumulative parameter values that can be achieved end-to-end. The example illustrates how the QNI can use the cumulative values collected in <QoS Available> to decide if a lower <Y.1541 QoS Class> than specified in <QoS Desired> is acceptable.

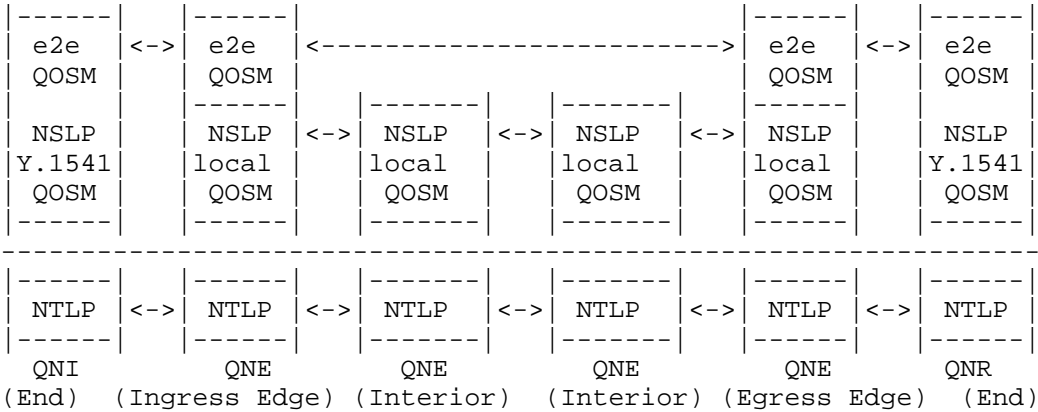

Figure 3: Example of Y.1541-QOSM Operation

4.5. Bit-Level QSPEC Example

This is an example where the QoS Desired specification contains the TMod-1 parameters and TMod extended parameters defined in this specification, as well as the Y.1541 Class parameter. The QoS Available specification utilizes the Latency, Jitter, and Loss parameters to enable accumulation of these parameters for easy comparison with the objectives desired for the Y.1541 Class.

This example assumes that all the parameters MUST be supported by the QNEs, so all M-flags have been set to 1.

```

0          1          2          3
0 1 2 3 4 5 6 7 8 9 0 1 2 3 4 5 6 7 8 9 0 1 2 3 4 5 6 7 8 9 0 1
+-----+-----+-----+-----+-----+-----+-----+-----+
| Vers. | QType=I | QSPEC Proc.=0/1 | 0 | R | R | R | Length = 23 |
+-----+-----+-----+-----+-----+-----+-----+-----+
| E | r | r | r | Type = 0 (QoS Des.) | r | r | r | r | Length = 10 |
+-----+-----+-----+-----+-----+-----+-----+-----+
| 1 | E | 0 | r | ID = 1 <TMOD-1> | r | r | r | r | Length = 5 |
+-----+-----+-----+-----+-----+-----+-----+-----+
| TMOD Rate-1 [r] (32-bit IEEE floating point number) |
+-----+-----+-----+-----+-----+-----+-----+-----+
| TMOD Size-1 [b] (32-bit IEEE floating point number) |
+-----+-----+-----+-----+-----+-----+-----+-----+
| Peak Data Rate-1 [p] (32-bit IEEE floating point number) |
+-----+-----+-----+-----+-----+-----+-----+-----+
| Minimum Policed Unit-1 [m] (32-bit unsigned integer) |
+-----+-----+-----+-----+-----+-----+-----+-----+
| Maximum Packet Size [MPS] (32-bit unsigned integer) |
+-----+-----+-----+-----+-----+-----+-----+-----+
| 1 | E | N | r | 15 | r | r | r | r | 1 |
+-----+-----+-----+-----+-----+-----+-----+-----+
| Peak Bucket Size [Bp] (32-bit IEEE floating point number) |
+-----+-----+-----+-----+-----+-----+-----+-----+
| 1 | E | N | r | 14 | r | r | r | r | 1 |
+-----+-----+-----+-----+-----+-----+-----+-----+
| Y.1541 QoS Cls. | (Reserved) |
+-----+-----+-----+-----+-----+-----+-----+-----+
| E | r | r | r | Type = 1 (QoS Avail) | r | r | r | r | Length = 11 |
+-----+-----+-----+-----+-----+-----+-----+-----+
| 1 | E | N | r | 3 | r | r | r | r | 1 |
+-----+-----+-----+-----+-----+-----+-----+-----+
| Path Latency (32-bit integer) |
+-----+-----+-----+-----+-----+-----+-----+-----+
| 1 | E | N | r | 4 | r | r | r | r | 4 |
+-----+-----+-----+-----+-----+-----+-----+-----+
| Path Jitter STAT1(variance) (32-bit integer) |
+-----+-----+-----+-----+-----+-----+-----+-----+
| Path Jitter STAT2(99.9%-ile) (32-bit integer) |
+-----+-----+-----+-----+-----+-----+-----+-----+
| Path Jitter STAT3(minimum Latency) (32-bit integer) |
+-----+-----+-----+-----+-----+-----+-----+-----+
| Path Jitter STAT4(Reserved) (32-bit integer) |
+-----+-----+-----+-----+-----+-----+-----+-----+
| 1 | E | N | r | 5 | r | r | r | r | 1 |
+-----+-----+-----+-----+-----+-----+-----+-----+
| Path Packet Loss Ratio (32-bit floating point) |
+-----+-----+-----+-----+-----+-----+-----+-----+
| 1 | E | N | r | 14 | r | r | r | r | 1 |

```

```

+-----+-----+-----+-----+-----+-----+-----+-----+-----+-----+
|Y.1541 QoS Cls.|                               (Reserved)                               |
+-----+-----+-----+-----+-----+-----+-----+-----+-----+-----+

```

Figure 4: An Example QSPEC (Initiator)

where 32-bit floating point numbers are as specified in [IEEE754].

4.6. Preemption Behavior

The default QNI behavior of tearing down a preempted reservation is followed in the Y.1541 QOSM. The restoration priority parameter described above does not rely on preemption.

5. IANA Considerations

This section defines additional codepoint assignments in the QSPEC Parameter ID registry and establishes one new registry for the Restoration Priority Parameter (and assigns initial values), in accordance with BCP 26 [RFC5226]. It also defines the procedural requirements to be followed by IANA in allocating new codepoints for the new registry.

5.1. Assignment of QSPEC Parameter IDs

This document specifies the following QSPEC parameters, which have been assigned in the QSPEC Parameter ID registry created in [RFC5975]:

<TMOD Extension> parameter (Section 3.1, ID=15)

<Restoration Priority> parameter (Section 3.2, ID=16)

5.2. Restoration Priority Parameter Registry

The Registry for Restoration Priority contains assignments for 3 fields in the 4-octet word and a Reserved section of the word.

This specification creates the following registry with the structure as defined below.

5.2.1. Restoration Priority Field

The Restoration Priority Field is 8 bits in length.

The following values are allocated by this specification:

0-2: assigned as specified in Section 3.2:

0: best-effort priority

1: normal priority

2: high priority

Further values are as follows:

3-255: Unassigned

The registration procedure is Specification Required.

5.2.2. Time to Restore Field

The Time to Restore Field is 4 bits in length.

The following values are allocated by this specification:

0-2: assigned as specified in Section 3.2:

0 - Unspecified Time-to-Restore

1 - Best Time-to-Restore: ≤ 200 ms

2 - Normal Time-to-Restore ≤ 2 s

Further values are as follows:

3-15: Unassigned

The registration procedure is Specification Required.

5.2.3. Extent of Restoration Field

The Extent of Restoration (EOR) Field is 4 bits in length.

The following values are allocated by this specification:

0-5: assigned as specified in Section 3.2:

0 - unspecified EOR

1 - high priority restored at 100%;
medium priority restored at 100%

- 2 - high priority restored at 100%;
medium priority restored at 80%
- 3 - high priority restored \geq 80%;
medium priority restored \geq 80%
- 4 - high priority restored \geq 80%;
medium priority restored \geq 60%
- 5 - high priority restored \geq 60%;
medium priority restored \geq 60%

Further values are as follows:

6-15: Unassigned

The registration procedure is Specification Required.

6. Security Considerations

The security considerations of [RFC5974] and [RFC5975] apply to this document.

The restoration priority parameter raises possibilities for theft-of-service attacks because users could claim an emergency priority for their flows without real need, thereby effectively preventing serious emergency calls from getting through. Several options exist for countering such attacks, for example:

- only some user groups (e.g., the police) are authorized to set the emergency priority bit
- any user is authorized to employ the emergency priority bit for particular destination addresses (e.g., police or fire departments)

There are no other known security considerations based on this document.

7. Acknowledgements

The authors thank Attila Bader, Cornelia Kappler, Sven Van den Bosch, and Hannes Tschofenig for helpful comments and discussion.

8. References

8.1. Normative References

- [IEEE754] ANSI/IEEE, "ANSI/IEEE 754-1985, IEEE Standard for Binary Floating-Point Arithmetic", 1985.
- [RFC2119] Bradner, S., "Key words for use in RFCs to Indicate Requirement Levels", BCP 14, RFC 2119, March 1997.
- [RFC5974] Manner, J., Karagiannis, G., and A. McDonald, "NSIS Signaling Layer Protocol (NSLP) for Quality-of-Service Signaling", RFC 5974, October 2010.
- [RFC5975] Ash, G., Bader, A., Kappler, C., and D. Oran, "QSPEC Template for the Quality-of-Service NSIS Signaling Layer Protocol (NSLP)", RFC 5975, October 2010.
- [Y.1221] ITU-T Recommendation Y.1221, "Traffic control and congestion control in IP based networks", March 2002.
- [Y.1540] ITU-T Recommendation Y.1540, "Internet protocol data communication service - IP packet transfer and availability performance parameters", December 2007.
- [Y.1541] ITU-T Recommendation Y.1541, "Network Performance Objectives for IP-Based Services", February 2006.
- [Y.2172] ITU-T Recommendation Y.2172, "Service restoration priority levels in Next Generation Networks", June 2007.

8.2. Informative References

- [COMPOSITION] Morton, A. and E. Stephan, "Spatial Composition of Metrics", Work in Progress, July 2010.
- [E.361] ITU-T Recommendation E.361, "QoS Routing Support for Interworking of QoS Service Classes Across Routing Technologies", May 2003.
- [RFC2205] Braden, B., Zhang, L., Berson, S., Herzog, S., and S. Jamin, "Resource ReSerVation Protocol (RSVP) -- Version 1 Functional Specification", RFC 2205, September 1997.
- [RFC2210] Wroclawski, J., "The Use of RSVP with IETF Integrated Services", RFC 2210, September 1997.

- [RFC2474] Nichols, K., Blake, S., Baker, F., and D. Black, "Definition of the Differentiated Services Field (DS Field) in the IPv4 and IPv6 Headers", RFC 2474, December 1998.
- [RFC2475] Blake, S., Black, D., Carlson, M., Davies, E., Wang, Z., and W. Weiss, "An Architecture for Differentiated Services", RFC 2475, December 1998.
- [RFC2597] Heinanen, J., Baker, F., Weiss, W., and J. Wroclawski, "Assured Forwarding PHB Group", RFC 2597, June 1999.
- [RFC3246] Davie, B., Charny, A., Bennet, J., Benson, K., Le Boudec, J., Courtney, W., Davari, S., Firoiu, V., and D. Stiliadis, "An Expedited Forwarding PHB (Per-Hop Behavior)", RFC 3246, March 2002.
- [RFC5226] Narten, T. and H. Alvestrand, "Guidelines for Writing an IANA Considerations Section in RFCs", BCP 26, RFC 5226, May 2008.
- [RFC5835] Morton, A. and S. Van den Berghe, "Framework for Metric Composition", RFC 5835, April 2010.
- [TRQ-QoS-SIG] ITU-T Supplement 51 to the Q-Series, "Signaling Requirements for IP-QoS", January 2004.

Authors' Addresses

Gerald Ash
AT&T Labs
200 Laurel Avenue South
Middletown, NJ 07748
USA

E-Mail: gash5107@yahoo.com

Al Morton
AT&T Labs
200 Laurel Avenue South
Middletown, NJ 07748
USA

Phone: +1 732 420 1571
Fax: +1 732 368 1192
E-Mail: acmorton@att.com
URI: <http://home.comcast.net/~acmacm/>

Martin Dolly
AT&T Labs
200 Laurel Avenue South
Middletown, NJ 07748
USA

E-Mail: mdolly@att.com

Percy Tarapore
AT&T Labs
200 Laurel Avenue South
Middletown, NJ 07748
USA

E-Mail: tarapore@att.com

Chuck Dvorak
AT&T Labs
180 Park Ave Bldg 2
Florham Park, NJ 07932
USA

Phone: + 1 973-236-6700

E-Mail: cdvorak@att.com

Yacine El Mghazli
Alcatel-Lucent
Route de Nozay
Marcoussis cedex 91460
France

Phone: +33 1 69 63 41 87

E-Mail: yacine.el_mghazli@alcatel.fr

