

Internet Engineering Task Force (IETF)
Request for Comments: 7148
Category: Standards Track
ISSN: 2070-1721

X. Zhou
ZTE Corporation
J. Korhonen
Broadcom
C. Williams
Consultant
S. Gundavelli
Cisco
CJ. Bernardos
UC3M
March 2014

Prefix Delegation Support for Proxy Mobile IPv6

Abstract

This specification defines extensions to the Proxy Mobile IPv6 protocol for allowing a mobile router in a Proxy Mobile IPv6 domain to obtain IP prefixes for its attached mobile networks using DHCPv6 prefix delegation. Network-based mobility management support is provided for those delegated IP prefixes just as it is provided for the mobile node's home address. Even if the mobile router performs a handoff and changes its network point of attachment, mobility support is ensured for all the delegated IP prefixes and for all the IP nodes in the mobile network that use IP address configuration from those delegated IP prefixes.

Status of This Memo

This is an Internet Standards Track document.

This document is a product of the Internet Engineering Task Force (IETF). It represents the consensus of the IETF community. It has received public review and has been approved for publication by the Internet Engineering Steering Group (IESG). Further information on Internet Standards is available in Section 2 of RFC 5741.

Information about the current status of this document, any errata, and how to provide feedback on it may be obtained at <http://www.rfc-editor.org/info/rfc7148>.

Copyright Notice

Copyright (c) 2014 IETF Trust and the persons identified as the document authors. All rights reserved.

This document is subject to BCP 78 and the IETF Trust's Legal Provisions Relating to IETF Documents (<http://trustee.ietf.org/license-info>) in effect on the date of publication of this document. Please review these documents carefully, as they describe your rights and restrictions with respect to this document. Code Components extracted from this document must include Simplified BSD License text as described in Section 4.e of the Trust Legal Provisions and are provided without warranty as described in the Simplified BSD License.

Table of Contents

1. Introduction	4
2. Terminology	6
3. Solution Overview	7
3.1. Stated Assumptions	7
3.2. Deployment Models	8
3.2.1. Delegating Router Co-located with Mobile Access Gateway	8
3.2.2. Delegating Router Co-located with Local Mobility Anchor	9
3.2.3. Static Configuration of Delegated Mobile Network Prefixes	12
4. Message Formats	12
4.1. Delegated Mobile Network Prefix Option	12
4.2. Status Codes	14
5. Operational Details	14
5.1. MAG Considerations	14
5.1.1. Extension to Binding Update List Entry Data Structure	14
5.1.2. Signaling Considerations	14
5.1.3. DHCP -- MAG Interactions	16
5.1.3.1. Delegating Router Co-located with Mobile Access Gateway	17
5.1.3.2. Delegating Router Co-located with Local Mobility Anchor	18
5.1.4. Packet Forwarding	19
5.2. LMA Considerations	20
5.2.1. Extensions to Binding Cache Entry Data Structure ...	20
5.2.2. Signaling Considerations	20
5.2.3. Packet Forwarding	22
5.3. Security Policy Database (SPD) Example Entries	22
6. Security Considerations	23
7. IANA Considerations	24
8. Acknowledgements	24
9. References	25
9.1. Normative References	25
9.2. Informative References	26

1. Introduction

Proxy Mobile IPv6 [RFC5213] enables network-based mobility management support for an IP host without requiring its participation in any IP mobility signaling. In Proxy Mobile IPv6 (PMIPv6), the mobile access gateway (MAG) performs the mobility management function on behalf of the mobile node (MN). The local mobility anchor (LMA) is the home agent for the MN and the topological anchor point. The mobility elements (LMA and MAGs) in the network allow an IP host to obtain an IPv4 address and/or a set of IPv6 addresses and be able to obtain IP mobility support for those IP address(es) within the Proxy Mobile IPv6 domain. In this context, the mobility management support is enabled for an individual IP host, which is the mobile node. The IPv4 home address or the IPv6 home network prefixes are logically bound to the link shared between the mobile access gateway and the mobile node, and only the mobile node can use those IP address(es) by configuring them on the interface attached to that link. Currently, there is no mobility support for the mobile networks attached to a mobile router (MR) in a Proxy Mobile IPv6 domain.

This specification defines extensions to the Proxy Mobile IPv6 protocol for allowing mobility support to the mobile networks attached to a mobile router. These extension include definition of a new mobility option that can be exchanged in the signaling messages between the mobile access gateway and the local mobility anchor. The mobile router can request the mobility entities in the Proxy Mobile IPv6 domain for delegated IP prefix(es) using DHCP prefix delegation extensions [RFC3633], static configuration of the prefixes, or mechanisms specific to the access technology. The mobility entities in the PMIPv6 network provide network-based mobility management support for those delegated prefixes just as it is supported for a home address. The delegated prefixes are hosted in the mobile network attached to the mobile router. IP mobility is ensured for all the IP nodes in the mobile network, even as the mobile router performs a handoff by changing its point of network attachment within the Proxy Mobile IPv6 domain. The local mobility anchor in the Proxy Mobile IPv6 domain will not track the individual IP nodes in the mobile network; it only tracks a single mobile router session that is hosting the mobile network and associates the delegated IP prefixes with that session. Although the protocol solution defined in this specification also allows signaling IPv4 subnets between the mobile access gateway and the local mobility anchor, the delegation of IPv4 subnets to the mobile router is out of the scope of this specification.

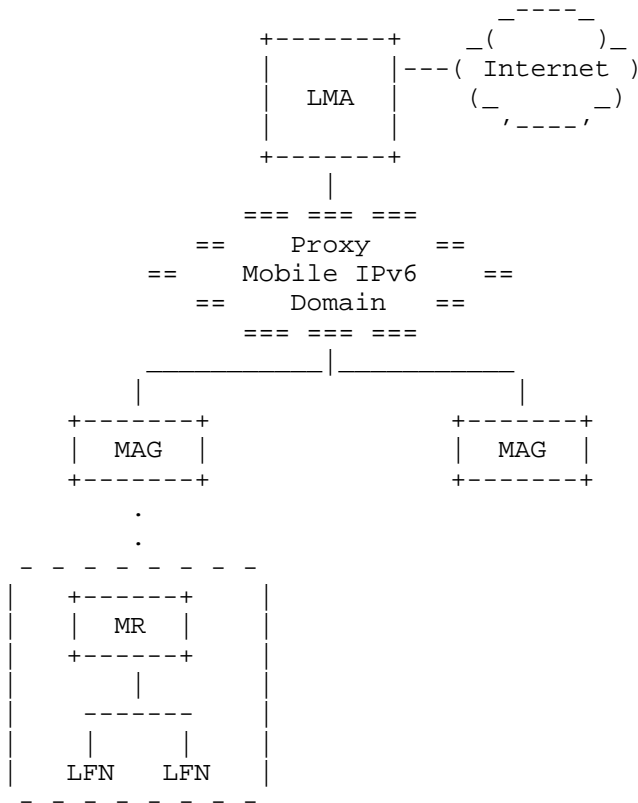

Figure 1: Mobile Router in Proxy Mobile IPv6 Domain

Within the context of this document, the definition of a mobile router extends the definition of a mobile node from [RFC5213] by adding routing capability between the mobile network and the point of attachment of the mobile router. Local fixed nodes (LFNs) are IP nodes in the mobile network; LFNs all move with the mobile router as a single cluster. As the mobile router moves, the LFNs are not aware of the mobility of the MR to a new point of attachment. Figure 1 illustrates a mobile router in a Proxy Mobile IPv6 domain.

The rest of this document identifies the protocol extensions and the operational details of the local mobility anchor and mobile access gateway for realizing prefix delegation support for Proxy Mobile IPv6.

2. Terminology

The key words "MUST", "MUST NOT", "REQUIRED", "SHALL", "SHALL NOT", "SHOULD", "SHOULD NOT", "RECOMMENDED", "MAY", and "OPTIONAL" in this document are to be interpreted as described in [RFC2119].

All the mobility-related terms used in this document are to be interpreted as defined in Proxy Mobile IPv6 specifications [RFC5213] and [RFC5844]. All the DHCP-related terms are to be interpreted as defined in DHCPv6 Prefix Delegation for Network Mobility (NEMO) [RFC6276], DHCPv6 Prefix Delegation (DHCPv6PD) [RFC3633], and Subnet Allocation Option for DHCPv4 [RFC6656]. This document also provides a context-specific explanation of the following terms used here and originally defined in the Mobile Network terminology document [RFC4885].

Mobile Router (MR)

The term "mobile router" is used to refer to an IP router whose mobility is managed by the network while being attached to a Proxy Mobile IPv6 domain. The mobile router is a mobile node as defined in [RFC5213] but with additional capabilities for supporting an attached mobile network. The MR's interface used for attachment to the mobile access gateway is referred to as the "egress interface". Any MR's interface used for attachment to the mobile network is referred to as the "ingress interface". The mobility entities in the Proxy Mobile IPv6 domain provide mobility for the IPv4/IPv6 address(es) assigned to the mobile node's egress link and also mobility support to the network prefixes hosted in the network attached to the mobile router.

Mobile Network

A mobile network is an IP network attached to a mobile router. There can be many IP nodes in this IP network. The mobile router is a gateway for these IP nodes for reaching other IP networks or the Internet. The mobile router and the attached IP networks move as a single cluster.

Delegated Mobile Network Prefix (DMNP)

The Delegated Mobile Network Prefix is an IPv4/IPv6 prefix delegated to a mobile router and is hosted in the mobile network. The IP nodes in the mobile network will be able to obtain IP address configuration from the DMNP and will have IP mobility support for that address configuration. The DMNP is topologically anchored on the local mobility anchor, and the mobility elements

in the Proxy Mobile IPv6 domain provide IP mobility support for the prefix by forwarding the mobile network traffic to the mobile router.

Local Fixed Node (LFN)

A local fixed node is an IP node in the mobile network. As the mobile router performs a handoff and changes its network point of attachment, the local fixed node moves along with the mobile router.

3. Solution Overview

This section lists the stated assumptions and provides an overview of the operation of this specification. This document references three different deployment scenarios and explains the protocol operation.

3.1. Stated Assumptions

- o The mobile router is a mobile node as defined in [RFC5213] but with additional capabilities for routing IP packets between its egress interface (interface used for attachment to the mobile access gateway) and any of its ingress interfaces (interfaces used for attachment to the mobile network).
- o This specification assumes that a mobile router is an IPv4 and/or IPv6 router without any capability for mobility management.
- o The mobile router can obtain the delegated IP prefix(es) for its attached mobile networks using DHCPv6 prefix delegation, static configuration, or mechanisms specific to access technology. This document assumes DHCPv6 prefix delegation [RFC3633] in conjunction with the Prefix Exclude Option [RFC6603] as the default mechanism for prefix assignment to the mobile node. It defines an interworking between the mobility entities and the DHCPv6 functional elements in a non-normative way. The mechanism that delegates IPv4 subnets to a mobile router is out of the scope of this specification.
- o The mobile router obtains the IP address configuration for its egress roaming interface as specified in [RFC5213] and [RFC5844]. The mobile router, along with its mobile networks, will be able to perform handoff, change its point of attachment in the network, and retain IP mobility support.
- o When using DHCPv6 prefix delegation, this document assumes that the mobile router uses its egress interface when making DHCPv6 requests.

3.2. Deployment Models

This section explains the protocol operation used to support prefix delegation in Proxy Mobile IPv6 for the following three deployment models: i) delegating router co-located with mobile access gateway, ii) delegating router co-located with local mobility anchor, and iii) static configuration of delegated prefixes. High-level message call flows between the mobile router, mobile access gateway, and the local mobility anchor are presented while explaining the protocol operation.

3.2.1. Delegating Router Co-located with Mobile Access Gateway

In this deployment scenario, the delegating router (DR) function, as specified in [RFC3633], is co-located with the mobile access gateway, and a requesting router (RR) function is enabled on the mobile router.

Figure 2 shows the high-level message call flow for this case. The mobile router attaches to the mobile access gateway, which triggers the Proxy Mobile IPv6 signaling between the mobile access gateway and the local mobility anchor, setting up the bidirectional tunnel between them (regular Proxy Mobile IPv6 registration). After that, the DHCPv6 requesting router function running on the mobile router sends a Solicit message requesting a prefix. This message is received by the DHCPv6 delegating router function running on the mobile access gateway. The mobile access gateway then sends a Proxy Binding Update message including a Delegated Mobile Network Prefix (DMNP) option carrying the ALL_ZERO value [RFC5213]. This serves as a request for the local mobility anchor to allocate a set of delegated prefixes, conveyed back in one or more DMNP options in a Proxy Binding Acknowledgement message. The DHCPv6-PD procedure is then completed as described in [RFC3633], ending with the delegating router sending a Reply message conveying the delegated prefixes. If the requesting router includes a Rapid Commit option in its Solicit message, it is preferable that the MAG respond directly with a Reply message rather than with an Advertise message, as described in [RFC3315], Section 17.2.3.

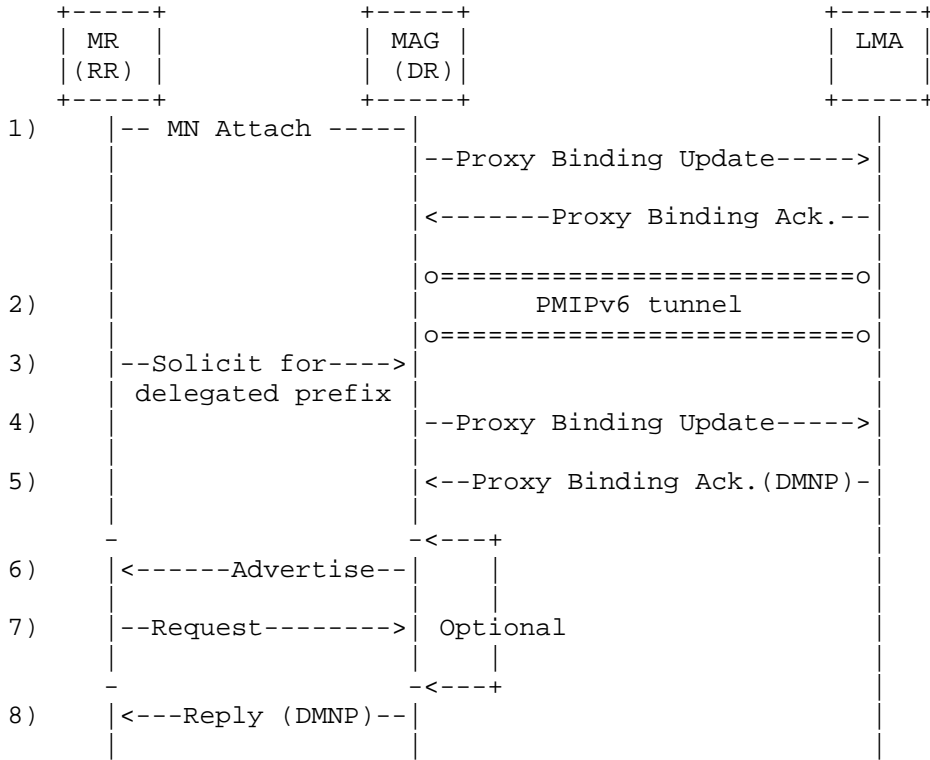

Figure 2: Delegating Router Co-located with Mobile Access Gateway

From an operational point of view, this is the simplest deployment option, as it keeps a single protocol interface between the mobile access gateway and the local mobility anchor.

3.2.2. Delegating Router Co-located with Local Mobility Anchor

In this deployment scenario, the delegating router (DR) function, as specified in [RFC3633], is co-located with the local mobility anchor; the requesting router (RR) function is enabled on the mobile router; and a DHCPv6 relay agent (DRA) function is co-located on the mobile access gateway.

Figure 3 shows the high-level message call flow for this case. The mobile router attaches to the mobile access gateway, which triggers the Proxy Mobile IPv6 signaling between the mobile access gateway and the local mobility anchor, setting up the bidirectional tunnel between them (regular Proxy Mobile IPv6 registration). After that, the DHCPv6 requesting router function running on the mobile router requests a prefix by sending a Solicit message. This message is

received by the DHCPv6 relay agent function running on the mobile access gateway, which then completes the DHCPv6 signaling, according to [RFC3315]. The relay agent function SHOULD include the relay agent remote-id option [RFC4649] into Relay-forward messages with appropriate identity information to enable correlation of mobile router identities used over DHCPv6 and PMIPv6.

Once the mobile access gateway gets the set of delegated prefixes from the delegating router function running on the local mobility anchor, the MAG conveys the delegated prefixes in a Proxy Binding Update. This ensures that the local mobility anchor properly routes the traffic addressed to the delegated prefixes via the PMIPv6 tunnel established with the mobile access gateway and that mobility is provided to these prefixes while the mobile router roams within the PMIPv6 domain. Note that the relay agent function in the mobile access gateway has to queue the Reply message for the duration of the PMIPv6 signaling (steps 10 and 11) before forwarding the Reply message to the requesting router. While this does not change anything from the DHCPv6-PD protocol's point of view, implementations will need to account for interactions between the timing of PMIPv6 signaling and the DHCPv6 timeout/retry logic.

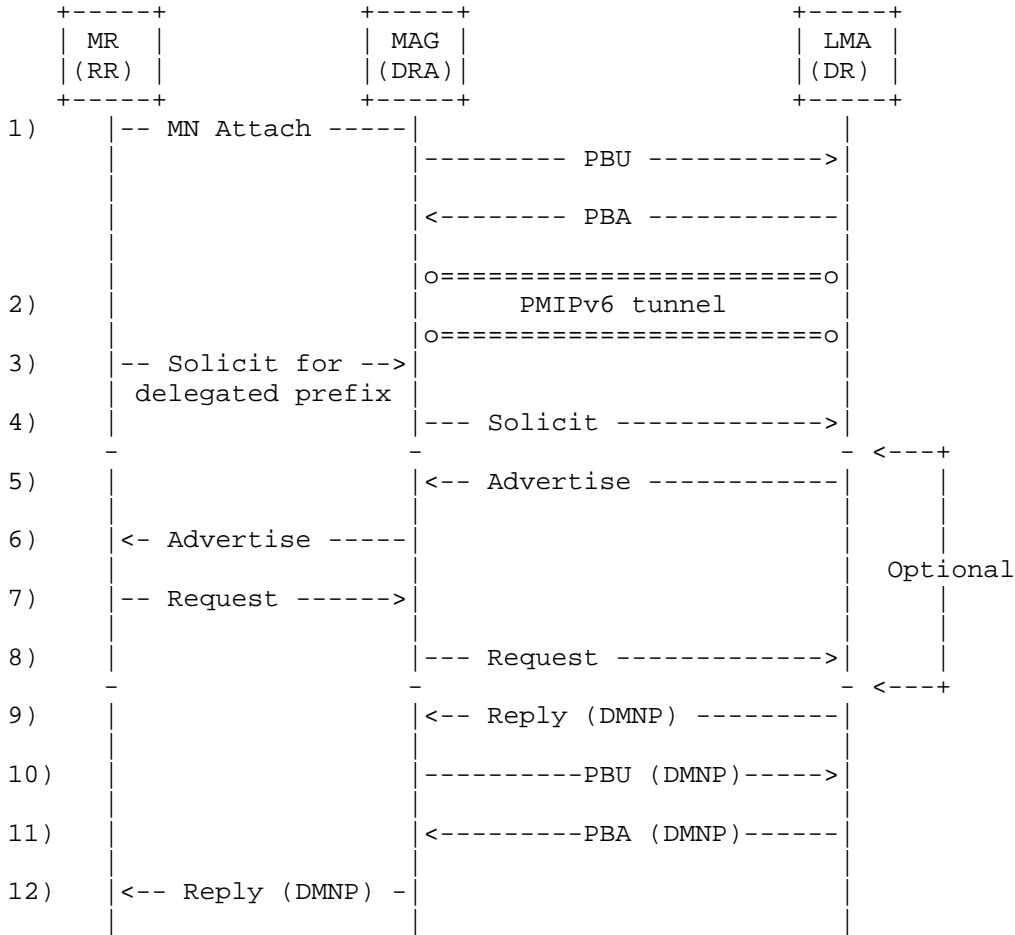

Figure 3: Delegating Router Co-located with Local Mobility Anchor

The DR function can also be located in other entities of the home network aside from the LMA. This deployment model requires some interworking between the DR and the LMA and is out of the scope of this specification. Note that this additional interworking would have no impact on the protocol between the LMA and MAG defined in this document.

3.2.3. Static Configuration of Delegated Mobile Network Prefixes

In this deployment scenario, the DMNPs of the mobile router are statically configured in the mobile node's policy profile [RFC5213]. The DMNPs are statically configured in the mobile network attached to the mobile router. The mobile router is the default-router for the mobile networks.

Figure 4 shows a high-level message call flow for this example. The mobile access gateway obtains statically configured mobile network prefixes from the policy profile and registers them with the local mobility anchor using the extensions specified in this document, that is, the use of the Delegated Mobile Network Prefix (DMNP) option in the Proxy Mobile IPv6 signaling. There is no explicit trigger from the mobile router for registering or de-registering those prefixes. As long as there is a mobility session for the mobile router's home address, the local mobility anchor enables mobility support for the mobile network prefixes.

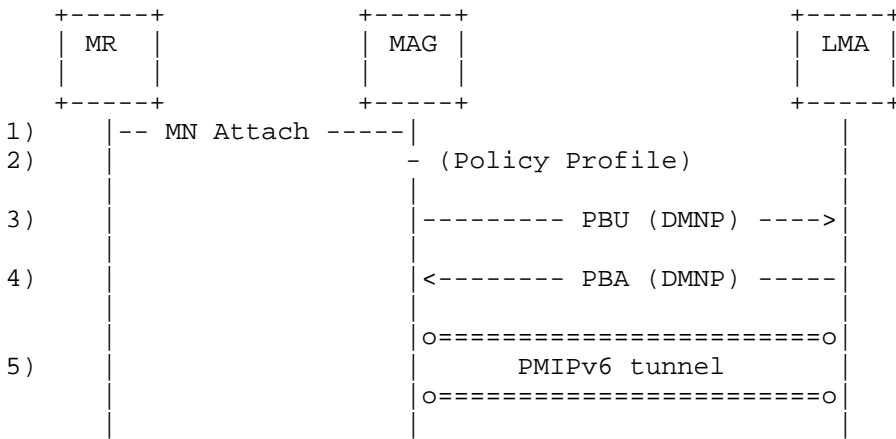

Figure 4: Static Configuration of Delegated Mobile Network Prefixes

4. Message Formats

This section defines extensions to Proxy Mobile IPv6 [RFC5213] protocol messages.

4.1. Delegated Mobile Network Prefix Option

A new mobility header option, the Delegated Mobile Network Prefix option, is defined for use with Proxy Binding Update and Proxy Binding Acknowledgement messages exchanged between a local mobility anchor and a mobile access gateway. This option is used for

exchanging the mobile router's IPv4/IPv6 DMNP. There can be multiple instances of the Delegated Mobile Network Prefix option present in a message.

The Delegated Mobile Network Prefix option has an alignment requirement of 8n+2. Its format is as follows:

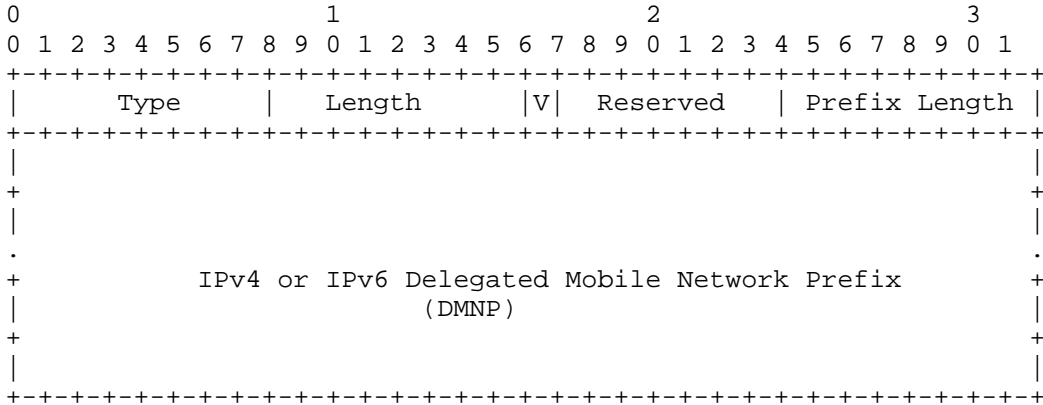

Type

55

Length

8-bit unsigned integer indicating the length of the option in octets, excluding the Type and Length fields.

IPv4 Prefix (V)

If the IPv4 Prefix (V) flag is set to a value of (1), then it indicates that the prefix that is included in the DMNP field is an IPv4 prefix. If the IPv4 Prefix (V) flag is set to a value of (0), then it indicates that the prefix that is included in the DMNP field is an IPv6 prefix.

Reserved

This field is unused for now. The value MUST be initialized to 0 by the sender and MUST be ignored by the receiver.

Prefix Length

8-bit unsigned integer indicating the number of leftmost bits covering the network part of the address contained in the Prefix field.

Delegated Mobile Network Prefix

Contains a mobile router's 4-byte IPv4 or a 16-byte IPv6 Delegated Mobile Network Prefix.

4.2. Status Codes

This document defines the following new status code values for use in the Proxy Binding Acknowledgement message. These values have been allocated from the same number space as defined in Section 6.1.8 of [RFC6275].

`NOT_AUTHORIZED_FOR_DELEGATED_MNP: 177`

Not authorized for DMNP

`REQUESTED_DMNP_IN_USE: 178`

Requested DMNP is in use

5. Operational Details

5.1. MAG Considerations

5.1.1. Extension to Binding Update List Entry Data Structure

In order to support this specification, the conceptual Binding Update List Entry (BULE) data structure [RFC5213] needs to be extended to include a Delegated Mobile Network Prefix (DMNP) list. Each entry in the list is used for storing an IPv4/IPv6 mobile network prefix delegated to the mobile router.

5.1.2. Signaling Considerations

During the mobile router's initial attachment procedure, the mobile access gateway obtains the mobile router's policy profile, as per the procedures defined in [RFC5213]. The mobile node's policy profile defined in [RFC5213] is extended to include a parameter that indicates Delegated Prefix support. If the policy profile indicates that the mobile router is authorized for Delegated Prefix support, then the considerations described next apply.

The mobile access gateway MUST include one or more Delegated Mobile Network Prefix (DMNP) options in the Proxy Binding Update message in order to request the local mobility anchor to allocate DMNP(s) for the mobile router.

If the mobile access gateway requests the local mobility anchor to perform the prefix assignment, then:

- o There MUST be exactly one instance of the Delegated Mobile Network Prefix option with an ALL_ZERO value and with the (V) flag set to a value of (0). This serves as a request to the local mobility anchor to allocate a set of IPv6 DMNPs.
- o There MUST be exactly one instance of the Delegated Mobile Network Prefix option with an ALL_ZERO value and with the (V) flag set to a value of (1). This serves as a request to the local mobility anchor to allocate a set of IPv4 DMNP.
- o If the received Proxy Binding Acknowledgement message has the status field value set to NOT_AUTHORIZED_FOR_DELEGATED_MNP (not authorized for DMNP), the mobile access gateway MUST NOT enable mobility support for any of the prefixes in the mobile network, and prefix delegation support has to be disabled.
- o If the received Proxy Binding Acknowledgement message has the status field value set to REQUESTED_DMNP_IN_USE (Requested DMNP is in use), the mobile access gateway MUST NOT enable mobility support for the requested prefixes. The mobile access gateway MAY choose to send Proxy Binding Update message requesting the local mobility anchor to perform the prefix assignment.

If the mobile access gateway provides the local mobility anchor with the prefix(es) to be allocated, then:

- o There MUST be exactly one instance of the Delegated Mobile Network Prefix option with NON_ZERO prefix value [RFC5213] for each of the mobile network prefixes that the mobile access gateway is requesting the local mobility anchor to allocate. The prefix value in the option is the prefix that is either statically configured for that mobile router in the mobile node's policy profile or obtained via interactions with the DHCP PD functions. This serves as a request to the local mobility anchor to allocate the requested IPv4/IPv6 prefix.

If the received Proxy Binding Acknowledgement message has the status field value set to 0 (Proxy Binding Update accepted), the mobile access gateway has to apply the following considerations.

- o The Delegated Mobile Network Prefix (DMNP) list in the mobile router's Binding Update List entry has to be updated with the allocated prefix(es). However, if the received message was in response to a de-registration request with a lifetime value of (0), then the DMNP list has to be removed along with the Binding Update List entry.
- o The mobile access gateway has to set up a policy-based route for forwarding the IP packets received from the mobile network (with the source IP address from any of the IPv4/IPv6 DMNPs) through the bidirectional tunnel set up for that mobile router. However, if the received message was in response to a de-registration request with a lifetime value of (0), then the created forwarding state has to be removed.

This specification assumes that all the mobile access gateways of a PMIPv6 domain support the same prefix delegation mechanism. Any differences will result in DMNPs getting de-registered and the mobile network losing the prefix(es). This would result in the attached local fixed nodes losing the assigned IP addresses. The mobile router MAY explicitly deprecate these prefixes. Alternatively, the lifetime of the addresses may expire.

5.1.3. DHCP -- MAG Interactions

This section describes the interactions between the DHCP and PMIPv6 logical entities running on the mobile access gateway. This section is applicable only for deployments that use DHCPv6-based prefix delegation (i.e., it does not apply if static configuration is used). As described next, these interactions vary slightly depending on the considered deployment model at the mobile access gateway (described in Section 3.2).

The mobile router, acting as a requesting router as described in [RFC3633], sends a Solicit message including one or more IA_PD option(s) to the delegating router / DHCPv6 relay agent co-located on the mobile access gateway. This message provides the needed trigger for the mobile access gateway to request the local mobility anchor to enable DMNP support for that mobility session. We next describe the subsequent interactions depending on the deployment model.

5.1.3.1. Delegating Router Co-located with Mobile Access Gateway

The mobile access gateway applies the considerations in Section 5.1.2 for requesting the local mobility anchor to enable delegated prefix support. For example, if the mobile router is soliciting an IPv4 prefix, the mobile access gateway includes in the Proxy Binding Update signaling a Delegated Mobile Network Prefix option with an ALL_ZERO value and with the (V) flag set to a value of (1).

The mobile access gateway, upon successfully completing the Proxy Binding Update signaling with the local mobility anchor (following the considerations described in Section 5.1.2), adds the DMNPs to the Binding Update List. Then, the mobile access gateway provides the obtained prefixes to the DHCPv6 delegating router for prefix assignment. The way in which these prefixes are passed to the DHCPv6 delegating router function is beyond the scope of this document.

- o In case the Proxy Binding Update signaling with the local mobility anchor is not completed successfully, for example, because the local mobility anchor is not authorized for DMNP or the requested prefix is in use, the DHCPv6 delegating router will send a Reply message to the requesting router with no IA_PREFIX suboptions and with a Status Code option as described in [RFC3633], Section 11.2.

The standard DHCPv6 considerations will be applied with respect to the interactions between the delegating router and the requesting router. The requesting router is provided with the delegated prefix(es), which can then be then advertised in the mobile network and therefore used by the local fixed nodes to autoconfigure IP addresses, allowing them to gain access to the Internet.

Any time the requesting router releases the delegated prefixes, the delegating router removes the assigned prefixes. To do so, the mobile access gateway will send an Updated Proxy Binding Update following the considerations described in Section 5.1.2 for de-registering those prefixes. The way in which the DHCPv6 delegating router triggers the mobile access gateway in order to de-register the prefixes is beyond the scope of this document.

In case the mobile router performs a handover and attaches to a different mobile access gateway, the following cases are possible:

- o The new mobile access gateway does not support the delegation of mobile network prefixes described in this specification. In this case, forwarding of the previously DMNPs is no longer performed.

- o The new mobile access gateway supports the delegation of mobile network prefixes described in this specification. There are two possible cases upon the reception of the Solicit message by the delegating router. If the MAG already knows the DMNPs, it conveys them in a DMNP option included in the Proxy Binding Update sent to the local mobility anchor, which then authorizes them based on: a) the content of the associated Binding Cache entry (if one exists), b) the user profile (if the allocation is static), or c) checking that the DMNPs are not already allocated. On the other hand, if the mobile access gateway is not aware of the DMNPs, it will include 0.0.0.0 / :: in a DMNP option included in the Proxy Binding Update sent to the LMA, which will provide the right prefixes back in the Proxy Binding Acknowledgement based on a) the content of the associated Binding Cache entry (if one exists), b) the profile (if static allocation is used), or c) dynamic assignment.

5.1.3.2. Delegating Router Co-Located with Local Mobility Anchor

A DHCPv6 relay agent function running on the mobile access gateway will forward the DHCP messages to the local mobility anchor that has the co-located delegating router function. The requesting router and the delegating router complete the DHCP messages related to prefix delegation.

During the DHCPv6 exchange, the standard DHCPv6 considerations apply with respect to the interactions between the delegating router, DHCPv6 relay agent, and requesting router.

The mobile access gateway learns from the co-located DHCPv6 relay agent the prefixes allocated by the delegating router. The way in which the mobile access gateway obtains this information from the DHCPv6 relay agent function is beyond the scope of this document.

The mobile access gateway will apply the considerations in Section 5.1.2 for requesting the local mobility anchor to enable delegated prefix support. The mobile access gateway will include exactly one instance of the Delegated Mobile Network Prefix option with NON_ZERO prefix value for each of the mobile network prefixes that the mobile access gateway is requesting the local mobility anchor to allocate. The prefix value(s) in the option will be the prefix(es) obtained via DHCP prefix delegation.

The mobile access gateway, upon successfully completing the Proxy Binding Update signaling with the local mobility anchor, will provide the obtained prefixes to the DHCPv6 relay agent for prefix assignment. The delegating router is provided with the delegated prefix(es) completing the standard DHCPv6 signaling. These prefixes

can then be advertised in the mobile network and therefore used by the local fixed nodes to autoconfigure IP addresses, allowing them to gain access to the Internet.

- o In case the Proxy Binding Update signaling with the local mobility anchor is not completed successfully, for example, because the local mobility anchor is not authorized for DMNP, the requested prefix is in use, or the delegated prefix(es) do not match the ones allocated by DHCP prefix delegation, the DHCPv6 relay agent MAY send a Reply message to the requesting router with no IA_PREFIX suboptions and with a Status Code option as described in [RFC3633], Section 11.2.

In case the mobile router performs a handover and attaches to a different mobile access gateway, the following cases are possible:

- o The new mobile access gateway does not support the delegation of mobile network prefixes described in this specification. In this case, forwarding of the previously delegated mobile network prefixes is no longer performed.
- o The new mobile access gateway supports the delegation of mobile network prefixes described in this specification. There are two possible cases upon the reception of the Solicit message by the DHCPv6 relay agent. If the MAG already knows the DMNPs, it conveys them in a DMNP option included in the Proxy Binding Update sent to the local mobility anchor, which then authorizes them based on: a) the content of the associated Binding Cache entry (if one exists), b) the user profile (if the allocation is static), or c) checking that the DMNPs are not already allocated. On the other hand, if the mobile access gateway is not aware of the DMNPs, it will include 0.0.0.0 / :: in a DMNP option included in the Proxy Binding Update sent to the LMA, which will provide the right prefixes back in the Proxy Binding Acknowledgement based on a) the content of the associated Binding Cache entry (if one exists), b) the profile (if static allocation is used), or c) dynamic assignment.

5.1.4. Packet Forwarding

On receiving an IP packet from a mobile router, the mobile access gateway MUST ensure, before tunneling the packet to the local mobility anchor, that there is an established binding for the mobile router and that the source IP address of the packet is a prefix delegated to that mobile router. If the source address of the received IP packet is not part of the DMNP, then the mobile access gateway MUST NOT tunnel the packet to the local mobility anchor.

On receiving an IP packet from the bidirectional tunnel established with the local mobility anchor, the mobile access gateway MUST first decapsulate the packet (remove the outer header) and then use the destination address of the (inner) packet to forward it on the interface through which the mobile router is reachable.

The above forwarding considerations are not applicable to the IP traffic sent/received to/from the mobile router's home address (IPv4 HoA / Home Network Prefix (HNP)). For the mobile router's home address traffic, forwarding considerations from [RFC5213] and [RFC5844] continue to apply.

5.2. LMA Considerations

5.2.1. Extensions to Binding Cache Entry Data Structure

In order to support this specification, the conceptual Binding Cache entry (BCE) data structure [RFC5213] needs to be extended to include the Delegated Mobile Network Prefix (DMNP) list. Each entry in the list represents a DMNP.

5.2.2. Signaling Considerations

If the Proxy Binding Update message does not include any Delegated Mobile Network Prefix option(s) (Section 4.1), then the local mobility anchor MUST NOT enable Delegated Prefix support for the mobility session, and the Proxy Binding Acknowledgement message that is sent in response MUST NOT contain any Delegated Mobile Network Prefix option(s).

If the Proxy Binding Update message includes one or more Delegated Mobile Network Prefix options, but the local mobility anchor is not configured with Delegated Prefix support, then the local mobility anchor will ignore the option(s) and process the rest of the option as specified in [RFC5213]. This would have no effect on the operation of the rest of the protocol. The Proxy Binding Acknowledgement message that is sent in response will not include any Delegated Mobile Network Prefix option(s).

If the Proxy Binding Update message has the Delegated Mobile Network Prefix option(s) and if the local mobility anchor is configured for Delegated Prefix support, then the local mobility anchor MUST enable the Delegated Mobile Network Prefix option for that mobility session. The Proxy Binding Acknowledgement message that is sent in response MUST include the Delegated Mobile Network Prefix option(s). The following considerations apply.

- o If there is at least one instance of the Delegated Mobile Network Prefix option with an ALL_ZERO [RFC5213] prefix value, then this serves as a request for the local mobility anchor to perform the assignment of one or more DMNPs.
 - * A Delegated Mobile Network option with an ALL_ZERO value and with the (V) flag set to a value of (0) is a request for the local mobility anchor to allocate one or more IPv6 prefixes.
 - * A Delegated Mobile Network option with an ALL_ZERO value and with the (V) flag set to a value of (1) is a request for the local mobility anchor to allocate one or more IPv4 prefixes.
 - * Inclusion of multiple instances of Delegated Mobile Network options with ALL_ZERO values, one with the (V) flag set to a value of (1) and another instance with the (V) flag set to a value of (0), is a request to allocate both IPv4 and IPv6 prefixes.
- o If there are no instances of the Delegated Mobile Network Prefix option present in the request with an ALL_ZERO value but a specific prefix value exists, then this serves as a request for the local mobility anchor to perform the allocation of the requested prefix(es).
 - * If any one of the requested prefixes are assigned to some other mobility node, or not from an authorized pool that the local mobility can allocate for that mobility session, then the Proxy Binding Update MUST be rejected by sending a Proxy Binding Acknowledgement message with the Status field set to REQUESTED_DMNP_IN_USE (Requested DMNP is in use).

Upon accepting the Proxy Binding Update, the local mobility anchor MUST send a Proxy Binding Acknowledgement message with the Status field set to 0 (Proxy Binding Update accepted).

- o The message MUST include one instance of the Delegated Mobile Network Prefix option for each of the allocated IPv4/IPv6 DMNPs.
- o The Delegated Mobile Network Prefix (DMNP) list in the mobile router's Binding Cache entry has to be updated with the allocated prefix(es). However, if the request is a de-registration request with a lifetime value of (0), the DMNP list has to be removed along with the Binding Cache entry.

- o A route (or a platform-specific equivalent function that sets up the forwarding) for each of the allocated prefixes over the tunnel has to be added. However, if the request is a de-registration request, with a lifetime value of (0), all the IPv4/IPv6 delegated prefix routes created for that session have to be removed.

5.2.3. Packet Forwarding

The local mobility anchor MUST advertise a connected route into the routing infrastructure for the IP prefixes delegated to all of the mobile routers that it is serving. This step essentially enables the local mobility anchor to be a routing anchor for those IP prefixes and be able to intercept IP packets sent to those mobile networks.

On receiving a packet from a correspondent node with the destination address matching any of the mobile router's DMNPs, the local mobility anchor MUST forward the packet through the bidirectional tunnel set up with the mobile access gateway where the mobile router is attached.

On receiving an IP packet from the bidirectional tunnel established with the mobile access gateway, the local mobility anchor MUST first decapsulate the packet (remove the outer header) and then use the destination address of the (inner) packet for forwarding decisions. The local mobility anchor MUST ensure that there is an established binding for the mobile router and that the source IP address of the packet is a prefix delegated to a mobile router reachable over that bidirectional tunnel.

The above forwarding considerations are not applicable to the IP traffic sent/received to/from the mobile router's home address (IPv4 HoA/HNP). For the mobile router's home address traffic, forwarding considerations from [RFC5213] and [RFC5844] continue to apply.

5.3. Security Policy Database (SPD) Example Entries

The use of DHCPv6, as described in this document, requires message integrity protection and source authentication. The IPsec security mechanism used by Proxy Mobile IPv6 [RFC5213] for securing the signaling messages between the mobile access gateway and the local mobility anchor can be used for securing the DHCP signaling between the mobile access gateway and the local mobility anchor.

The Security Policy Database (SPD) and Security Association Database (SAD) entries necessary to protect the DHCP signaling is specified below. The format of these entries is based on [RFC4877] conventions. The SPD and SAD entries are only example configurations. A particular implementation of mobile access gateway

and local mobility anchor implementation can configure different SPD and SAD entries as long as they provide the required security for protecting DHCP signaling messages.

For the examples described in this document, a mobile access gateway with address "mag_address_1" and a local mobility anchor with address "lma_address_1" are assumed.

mobile access gateway SPD-S:

- IF local_address = mag_address_1 &
remote_address = lma_address_1 & proto = UDP &
local_port = any & remote_port = DHCP
Then use SA1 (OUT) and SA2 (IN)

mobile access gateway SAD:

- SA1(OUT, spi_a, lma_address_1, ESP, TRANSPORT):
local_address = mag_address_1 &
remote_address = lma_address_1 &
proto = UDP & remote_port = DHCP
- SA2(IN, spi_b, mag_address_1, ESP, TRANSPORT):
local_address = lma_address_1 &
remote_address = mag_address_1 &
proto = UDP & local_port = DHCP

local mobility anchor SPD-S:

- IF local_address = lma_address_1 &
remote_address = mag_address_1 & proto = UDP &
local_port = DHCP & remote_port = any
Then use SA2 (OUT) and SA1 (IN)

local mobility anchor SAD:

- SA2(OUT, spi_b, mag_address_1, ESP, TRANSPORT):
local_address = lma_address_1 &
remote_address = mag_address_1 &
proto = UDP & local_port = DHCP
- SA1(IN, spi_a, lma_address_1, ESP, TRANSPORT):
local_address = mag_address_1 &
remote_address = lma_address_1 &
proto = UDP & remote_port = DHCP

6. Security Considerations

The Delegated Mobile Network Prefix option defined in this specification is for use in Proxy Binding Update and Proxy Binding Acknowledgement messages. This option is carried like any other mobility header option as specified in [RFC5213]. Therefore, it inherits from [RFC5213] its security guidelines and does not require any additional security considerations.

The use of DHCPv6 in this specification is as defined in the DHCPv6 base specification [RFC3315] and DHCPv6 prefix delegation specification [RFC3633]. The security considerations specified in those specifications apply to this document.

If IPsec is used, the IPsec security association that is used for protecting the Proxy Binding Update and Proxy Binding Acknowledgement also needs to be used for protecting the DHCPv6 signaling between the mobile access gateway and the local mobility anchor. Considerations specified in Section 5.3 identify the extensions to security policy entries [RFC4301]

7. IANA Considerations

- o This specification defines a new mobility header option, the Delegated Mobile Network Prefix option. This mobility option is described in Section 4.1. The type value 55 for this message has been allocated from the "Mobility Options" registry at <http://www.iana.org/assignments/mobility-parameters>.
- o This document also defines two new status code values for use in the Proxy Binding Acknowledgement message, as described in Section 4.2. These status codes are NOT_AUTHORIZED_FOR_DELEGATED_MNP (not authorized for DMNP) with a status code value of 177 and REQUESTED_DMNP_IN_USE (Requested DMNP is in use) with a status code value of 178. These values have been assigned from the same number space as allocated for other status codes [RFC6275].

8. Acknowledgements

The authors would like to acknowledge Ryuji Wakikawa, Alexandru Petrescu, Behcet Sarikaya, Seil Jeon, Basavaraj Patil, Brian Haberman, and Michal Hoefft for all the discussions and reviews of this document.

The work of Carlos J. Bernardos has also been partially supported by the European Community's Seventh Framework Programme (FP7-ICT-2009-5) under grant agreement n. 258053 (MEDIEVAL project) and by the Ministry of Science and Innovation of Spain under the QUARTET project (TIN2009-13992-C02-01).

9. References

9.1. Normative References

- [RFC2119] Bradner, S., "Key words for use in RFCs to Indicate Requirement Levels", BCP 14, RFC 2119, March 1997.
- [RFC3315] Droms, R., Bound, J., Volz, B., Lemon, T., Perkins, C., and M. Carney, "Dynamic Host Configuration Protocol for IPv6 (DHCPv6)", RFC 3315, July 2003.
- [RFC3633] Troan, O. and R. Droms, "IPv6 Prefix Options for Dynamic Host Configuration Protocol (DHCP) version 6", RFC 3633, December 2003.
- [RFC4301] Kent, S. and K. Seo, "Security Architecture for the Internet Protocol", RFC 4301, December 2005.
- [RFC4649] Volz, B., "Dynamic Host Configuration Protocol for IPv6 (DHCPv6) Relay Agent Remote-ID Option", RFC 4649, August 2006.
- [RFC4877] Devarapalli, V. and F. Dupont, "Mobile IPv6 Operation with IKEv2 and the Revised IPsec Architecture", RFC 4877, April 2007.
- [RFC5213] Gundavelli, S., Leung, K., Devarapalli, V., Chowdhury, K., and B. Patil, "Proxy Mobile IPv6", RFC 5213, August 2008.
- [RFC5844] Wakikawa, R. and S. Gundavelli, "IPv4 Support for Proxy Mobile IPv6", RFC 5844, May 2010.
- [RFC6275] Perkins, C., Johnson, D., and J. Arkko, "Mobility Support in IPv6", RFC 6275, July 2011.
- [RFC6276] Droms, R., Thubert, P., Dupont, F., Haddad, W., and C. Bernardos, "DHCPv6 Prefix Delegation for Network Mobility (NEMO)", RFC 6276, July 2011.
- [RFC6603] Korhonen, J., Savolainen, T., Krishnan, S., and O. Troan, "Prefix Exclude Option for DHCPv6-based Prefix Delegation", RFC 6603, May 2012.

9.2. Informative References

- [RFC4885] Ernst, T. and H-Y. Lach, "Network Mobility Support Terminology", RFC 4885, July 2007.
- [RFC6656] Johnson, R., Kinnear, K., and M. Stapp, "Description of Cisco Systems' Subnet Allocation Option for DHCPv4", RFC 6656, July 2012.

Authors' Addresses

Xingyue Zhou
ZTE Corporation
No.50 Software Avenue, Yuhuatai District
Nanjing
China

Phone: +86-25-8801-4634
EMail: zhou.xingyue@zte.com.cn

Jouni Korhonen
Broadcom
Porkkalankatu 24
Helsinki FIN-00180
Finland

EMail: jouni.nospam@gmail.com

Carl Williams
Consultant
San Jose, CA
USA

EMail: carlw@mcsr-labs.org

Sri Gundavelli
Cisco
170 West Tasman Drive
San Jose, CA 95134
USA

EMail: sgundave@cisco.com

Carlos J. Bernardos
Universidad Carlos III de Madrid
Av. Universidad, 30
Leganes, Madrid 28911
Spain

Phone: +34 91624 6236
EMail: cjbc@it.uc3m.es
URI: <http://www.it.uc3m.es/cjbc/>

